



JARRAFF

By *Pinotti*

Jarraff wheels shown in transport mode.



Articulated undercarriage, hydrostatic all-time four-wheel drive, 10-ton winch, and tire and track options enables access to the most difficult terrains.

JARRAFF ALL-TERRAIN TREE TRIMMER

SAFER

Keep your operators safe in a ROPS and FOPS, climate-controlled cab full of safety features like LED lights, cameras, dielectric-tested boom, safety switches, and more.

EASIER FASTER

Reduces your tree trimming work to a one-person, one-machine job. Touch screen, joystick controls, and on-site training makes start-up fast and effective.

Performs 5-10 times the work daily over conventional methods like bucket trucks, lifts, and climbers. The Jarraff is the most advanced, automated method for trimming available.

Seventy-five foot reach, 360-degree boom rotation and 180-degree saw blade rotation enables unparalleled access and precision cutting to ANSI standards.

ACCURATE

PROFITABLE

Exceptional longevity and hours of use, low down time, ease of service, and low total cost of ownership. Forty-year reputation for parts and service response.

Designed for Right-of-Way maintenance for utilities and sold direct to utilities and their contractors. Fully manufactured in the U.S. by woman-owned Jarraff Industries.

FOR THE SMARTER WAY TO TRIM TREES



THE JARRAFF ALL-TERRAIN TREE TRIMMER

Manufactured in the USA, the Jarraff All-Terrain Tree Trimmer is designed for Right-of-Way maintenance operations in the most difficult to the most sensitive terrain. The Jarraff is simply the smartest way to trim trees. Contact Jarraff Industries today.

A large yellow tracked tree trimmer is positioned on a dirt path in a dense forest. The machine has a long, white boom extending upwards and to the left. A worker wearing a hard hat and a high-visibility vest stands on the side of the machine. The background is filled with tall, thin trees.

HE'LL DO MORE IN ONE DAY
with a Jarraff All-Terrain Tree Trimmer
Than the Entire Crew Will in One Week
and Go Home Safe



JARRAFF®
All-Terrain Tree Trimmer
Designed for heavy-duty Right-of-Way
maintenance and trimming.



MINI-JARRAFF®
Urban Tree Trimmer
Ideal for trimming urban landscapes and
residential neighborhoods.



LINEBACKER®
Brush Cutter

Designed for land clearing, ROW maintenance,
storm clean-up, and fire control.



JARRAFF

By *Pinck*

JARRAFF.COM | 800-767-7112

Jarraff Industries LLC
1731 Gault Street
St. Peter, MN 56082

Jarraff FEATURES

The Jarraff's **MAINTENANCE-FREE BOOM BELT DRIVE SYSTEM** offers quiet operation, reduces downtime and requires only a periodic adjustment.



The **CUMMINS QSF 3.8L 130HP TIER 4 DIESEL ENGINE** meets all EPA regulations, while improving overall fuel efficiency and roading speed. The engine positioning allows for easy access and service.



The Jarraff's **PUSH BLADE** features an improved approach angle and updated blade design for better field performance. Push button controls make brush clean-up fast and efficient.

Jarraff FEATURES

Jarraff's innovative **TOUCH SCREEN CONTROL CENTER** gives the user unmatched operational input through features like keyless-password controlled starting, fingertip adjustable engine control, back up screen and more, all through a 7" screen



INTERNALLY MOUNTED HOSE REEL protects crucial hydraulic hoses from the elements and from any falling debris.

Patented **ROTATING SAW HEAD** rotates 180°, providing the operator unmatched cut quality, accuracy and speed. A specially designed tooth guard adds an additionally level of operator safety.



JARRAFF.COM | 800-767-7112

Jarraff Industries LLC
1731 Gault Street, St. Peter, MN 56082

4-Wheel Drive SPECIFICATIONS

ELECTRICAL SYSTEM

- Power Requirements
- 12V - DC

BOOM, SAW HEAD, WINCH & PUSH BLADE

- Boom Construction - High-tensile, non-conductive fiberglass
- Saw Blade Diameter - 24 inches (610 mm)
- Saw Blade RPM - 3200 RPM
- Push Blade - 8 feet wide, hydraulically powered
- Winch - 20,000 lb winch (9072 kg); 150 feet (45.7 m) of 5/8 inch (16 mm) cable included with chain and hook

OPERATIONAL CAPACITIES

- Maximum Cutting height - 75 feet (22.9 m)
- Rotation - 360° on turntable
- Rotation - 180° on boom
- Controls - Joysticks, Foot Travel Pedal and Service Brake

PHYSICAL SPECIFICATIONS

- Traveling Length - 41 feet 6 inches (12.65 m)

4-Wheel Drive Model (Standard Tire Size - 28L x 26)	
Undercarriage	Articulation
Weight	24,820 lbs (11,260 Kg) Full Wet Weight
Ground Pressure	6.7 PSI (0.46 Bar)
Width	Transport - 8 feet 6 inch (2.62 m) Operating - 10 feet 4 inch (3.15 m)
Carrier Length	25 ft (7.62 m)
Height	11 feet 6 inch (3.51 m)

ADDITIONAL TIRE SIZES AVAILABLE:

Tire Size	Ground Pressure
23.1 x 26	8.2 PSI* (0.56 Bar)
67 x 3400 x 26	9.1 PSI* (0.63 Bar)
66 x 4300 x 25	5.3 PSI* (0.36 Bar)

*Ground pressure @ 3" penetration and manufacturer recommended tire pressure

4-Wheel Drive SPECIFICATIONS

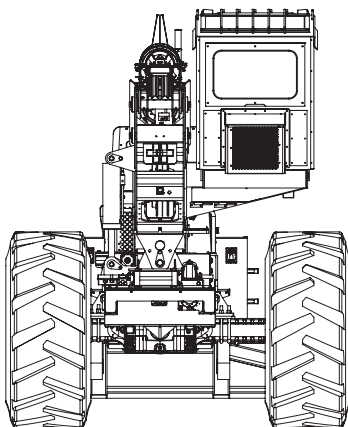
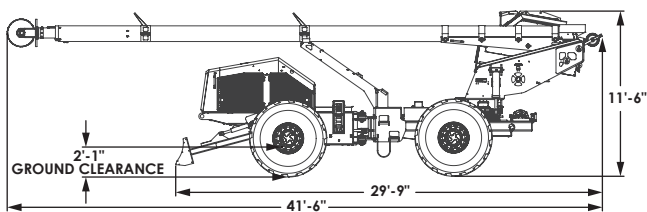
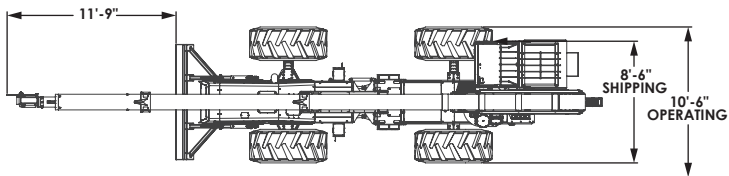

JARRAFF.COM | 800-767-7112

Jarraff Industries LLC
1731 Gault Street, St. Peter, MN 56082

Steel & Rubber Track SPECIFICATIONS

ELECTRICAL SYSTEM

- Power Requirements
- 12V - DC

BOOM, SAW HEAD, WINCH & PUSH BLADE

- Boom Construction - High-tensile, non-conductive fiberglass
- Saw Blade Diameter - 24 inches (610 mm)
- Saw Blade RPM - 3200 RPM
- Push Blade - 8 feet wide, hydraulically powered
- Winch - 20,000 lb winch (9072 kg); 150 feet (45.7 m) of 5/8 inch (16 mm) cable included with chain and hook

OPERATIONAL CAPACITIES

- Maximum Cutting height - 75 feet (22.9 m)
- Rotation - 360° on turntable
- Rotation - 180° on boom
- Controls - Foot Pedals and Joysticks

PHYSICAL SPECIFICATIONS

- Traveling Length - 41 feet 6 inches (12.65 m)

	Steel & Rubber Track
Undercarriage	Steel & Rubber Track
Weight	24,660 lbs (11,200 Kg) Full Wet Weight
Ground Pressure	3.0 PSI (0.207 Bar)
Width	8 feet 4 inch (2.54 m)
Carrier Length	21 ft (6.40 m)
Height	11 feet 3 inch (3.43 m)

Steel & Rubber Track SPECIFICATIONS

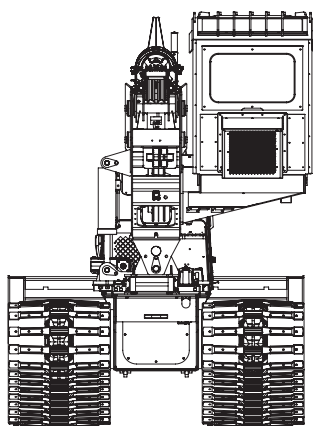
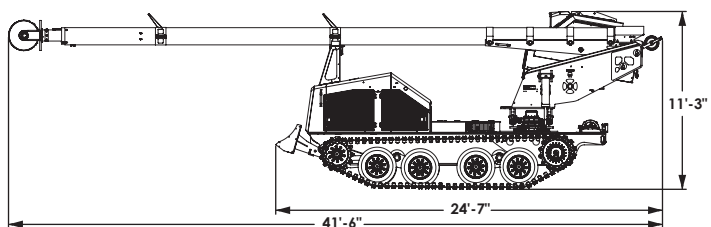
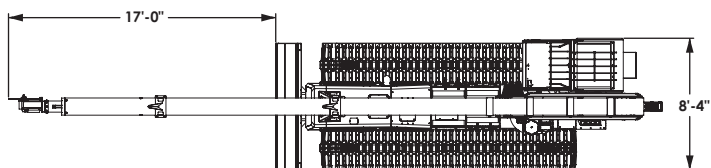

JARRAFF.COM | 800-767-7112

Jarraff Industries LLC
1731 Gault Street, St. Peter, MN 56082

PRODUCT SUPPORT

Quality parts and superior construction go into every piece of Jarraff equipment. Accessible machine design allows service work to be done quickly and easily, and a full maintenance schedule is included with each machine. Jarraff Industries equipment is field-proven in even the toughest



conditions and is backed by a knowledgeable service staff, ready to help you. Jarraff prides itself on OEM parts availability and next day air service from its 10,000 sq. ft. parts and service facility in St. Peter, MN to minimize your downtime. Jarraff's product support staff can walk you through repairs or arrange for a qualified field technician in your area. You can expect quality construction, service and support with everything you buy from Jarraff Industries.

Call Parts & Service: 800-767-7113

E-mail: parts@jarraff.com

AUTHORIZED SERVICE PROVIDERS

Authorized service providers from Jarraff Industries offer experienced mechanics and Jarraff OEM parts making it easier than ever to maintain your equipment.

Services Offered:

- Boom repair
- Part installation
- General maintenance
- Hydraulic service & more

Maximize productivity and extend the life of your Jarraff equipment.

Your Jarraff Product Support specialist will be happy to arrange for service at one of our sixty-two Jarraff Authorized Service Centers.



JARRAFF.COM | 800-767-7112

Jarraff Industries LLC
1731 Gault Street, St. Peter, MN 56082